

MOBILE HYDRAULIC PULLER

BETEX HXPM 100 - 2/3-arm puller, self-centering, 100 ton capacity

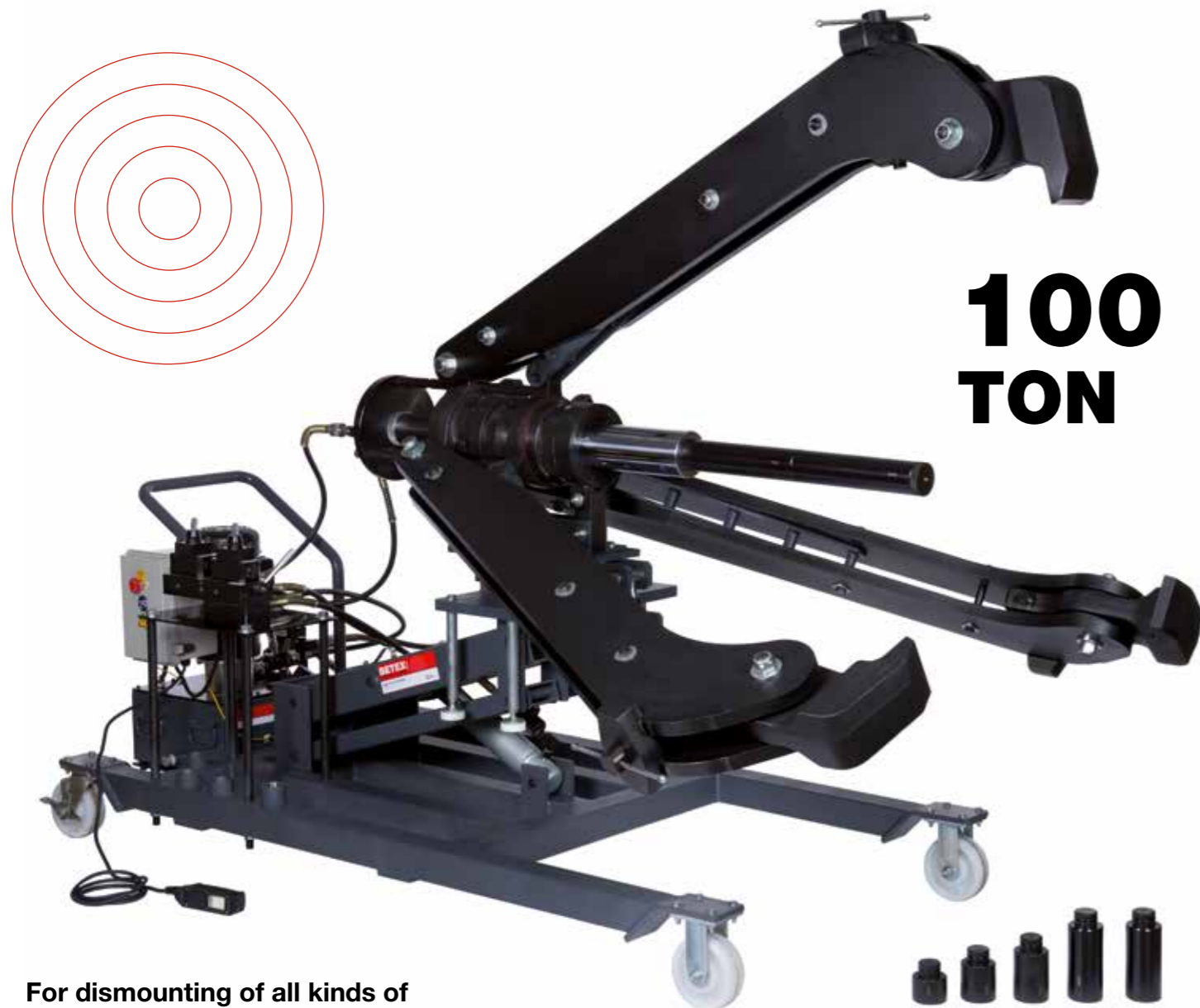

For dismantling of all kinds of transmission parts such as bearings, couplings, gears, wheels etc.

- **Practical**
The puller is self-centering, easy to manoeuvre and adjustable in height. The puller is easy to convert into a 2- or 3-arm version. The arms slide inwards or outwards simultaneously.
- **Fast**
The complete stroke is 270 mm. Seven adapters (extensions) with a total length of 1125 mm are included.
- **Strong**
The greater the pulling force, the tighter the jaws grip the object concerned! The arms cannot bend or deflect.
- **Safe**
Integral safety release valve prevents overload and ensures you never exceed maximum power capacity.

Advantages

- Prevent damage to shaft and component
- Easily operated by one person.
- Efficient and saves time
- Including 7 adapters
- Including remote control

MOBILE HYDRAULIC PULLER

BETEX HXPM 100 - 2/3-arm puller, self-centering, 100 ton capacity

- Double-acting cylinder for holding, opening and closing the jaws for safe, secure grip on job
- Electro-hydraulic pump, 400V - 700 bar, operates the cylinder. This is a 2-stage pump with oil delivery 9.5 liters/minute at 7 bar pressure
- Self-centering: the arms slide inwards or outwards simultaneously
- The design prevents the puller jaws from slipping or deflecting
- The puller is easy to convert into a 2- or 3-arm version
- The puller is adjustable 5° vertically
- The cart has two swivel castors (self-locking) and two rigid castors
- The hydraulic cylinder is 2-stage, spring-return type with a max. working pressure of 700 bar (100 tons)
- Seven adapters (extensions) are included with a total length of 1125 mm
- Adjustable jaw tips for optimal grip

TIP: use in combination with UHAP2800 high pressure pump, see page 107.



Valve block



Pump detail



Adjustable jaw tips for more grip

Type	HXPM 100 - 2/3-arm
Art. no.	700015
Capacity ton	100
Max. stroke mm	270
Max. spread mm	1500
Min. spread mm	200
Max. shaft length mm	1215
Operation: - Main cylinder - Height adjustment - self-centering jaws	electro-hydraulic pump EP420D, 400V - 6A, 50 Hz, with remote control
Seven adapters mm	2x Ø70 L=300 mm, 2x Ø70 L=150 mm
Total length: 1125 mm	1x Ø70 L=100 mm, 1x Ø70 L=75 mm, 1x Ø70 L=50 mm
Min. height from centre mm	820
Max. height from centre mm	1320
Gauge bar	700 bar
Dimensions LxWxH mm	2790 x 1030 x 1410
Weight kg	1120

